

AC Solid State Relay



S5 SERIES



Features

Sall size, medium power SSR
 Max. load current at 25A
 Dielectric strength between input and output at 3,000V/1 min.

Wider input voltage (L, M, H)
 UL/CSA/VDE/TÜV standard approved
 Optional heat-sink available (P.67)

Type Information

S 5 C - 2 2 5 L V

Zero-cross-circuit C : Built-in N : Not Built-in (*)	Standard load voltage 2 : 100V, 200	Max. load current 25 : 25A	Input voltage range L : DC4 ~ 8V M : DC8 ~ 18V H : DC18 ~ 28V	Approved Standard V : UL, CSA, VDE, TÜV approved
------------------------------------------------------------	----------------------------------------	-------------------------------	------------------------------------------------------------------------	-----------------------------------------------------

* Manufactured to order

Characteristics

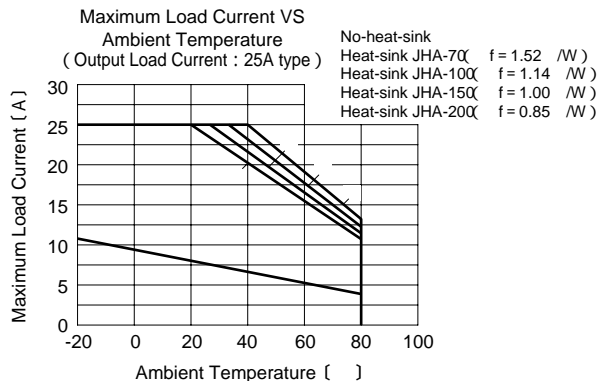

Description in the catalogue is subject to change without notice. Please read the specifications thoroughly before using. Please contact JEL SYSTEM for further information.

Dimensions (mm)

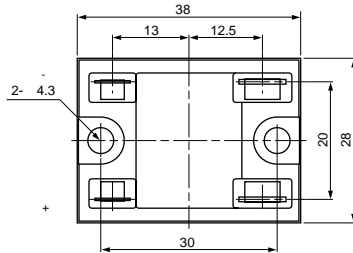

Torque range
Outer case 1.5 N · m(MAX)

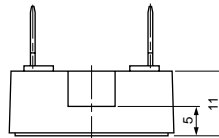
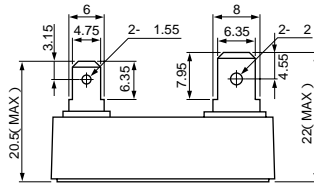

(1, 2 : Faston terminal # 250 t = 0.8 Tin plate
3, 4 : Faston terminal # 187 t = 0.5 Tin plate)

Equivalent Circuit

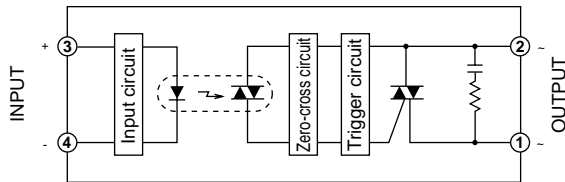

Model	Zero-cross-circuit
S5C-225 * *	
S5N-225 * *	x

Description in the catalogue is subject to change without notice. Please read the specifications thoroughly before using.
Please contact JEL SYSTEM for further information.

Ratings

(Ta = 25)

	Item	Symbols	S5C-225LV	S5C-225MV	S5C-225HV	S5N-225LV	S5N-225MV	S5N-225HV	Units
Output	Rated Load Voltage		120、240						V _{ACrms}
	Maximum Load Current	I _{OMAX}	25						A _{ACrms}
	Maximum Load Voltage	V _{OMAX}	264						V _{ACrms}
	Peak Repetitive Off State Voltage	V _{DRM}	600						V
	Peak 1 Cycle Surge Current	I _{SURGE}	225 (50Hz)						A
	Frequency	f	50、60						Hz
Input	Maximum Input Voltage	V _{IMAX}	8	18	28	8	18	28	V _{DC}
	Input Impedance	R _{IN}	270 ± 20 %	680 ± 20 %	1500 ± 20 %	270 ± 20 %	680 ± 20 %	1500 ± 20 %	
General	Dielectric Strength	V _{ISO}	3,000 / 1min. (Between input-output-case)(Rh40 ~ 60 %)						V _{ACrms}
	Isolation Resistance	R _{ISO}	10 ⁸ and above DC500V (Between input-output-case)(Rh40 ~ 60 %)						
	Operating Temperature Range	T _{OPR}	- 20 ~ + 80						
	Storage Temperature Range	T _{STG}	- 30 ~ + 100						

Electrical Characteristics

(Ta = 25)

	Item	Symbols	S5C-225LV	S5C-225MV	S5C-225HV	S5N-225LV	S5N-225MV	S5N-225HV	Units
Output	Load Voltage Range	V _O	35 ~ 264						V _{ACrms}
	Off State Leakage Current	I _{LEK}	5.0 and below (V _O = 200V)						mA _{ACrms}
	On State Voltage Drop	V _{SAT}	1.5 and below						V _{ACrms}
	Minimum Load Current	I _{OMIN}	100						mA
Input	Input Voltage Range	V _I	4 ~ 8	8 ~ 18	18 ~ 28	4 ~ 8	8 ~ 18	18 ~ 28	V _{DC}
	Operate Voltage	V _P	4 and below	8 and below	18 and below	4 and below	8 and below	18 and below	V _{DC}
	Release Voltage	V _D	1 and above						V _{DC}
General	Operate Time	T _{ON}	1/2 Cycle + 1ms and below			1ms and below			
	Release Time	T _{OFF}	1/2 Cycle + 1ms and below						
	Capacitance	C _{IO}	80 and below						PF
	Zero Cross Turn On		Built In			Not Built In			
	Approved Standards		UL、CSA、VDE、TÜV						

Description in the catalogue is subject to change without notice. Please read the specifications thoroughly before using. Please contact JEL SYSTEM for further information.

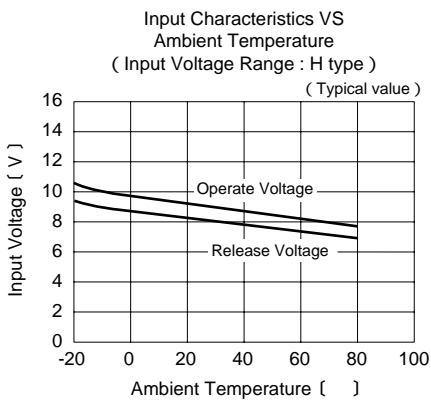
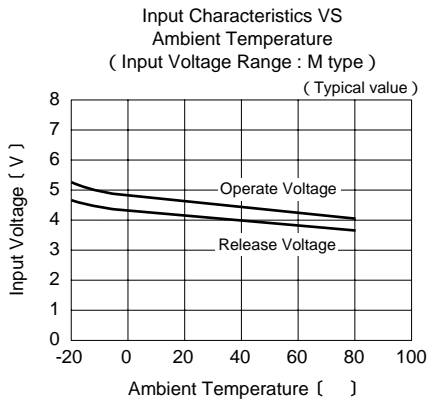
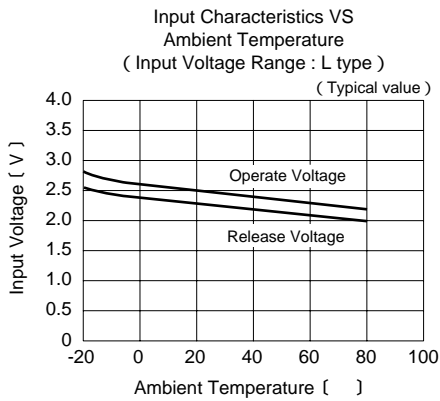
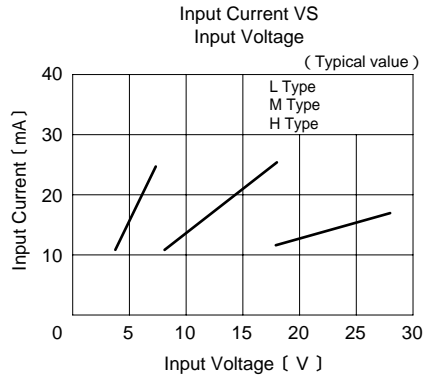
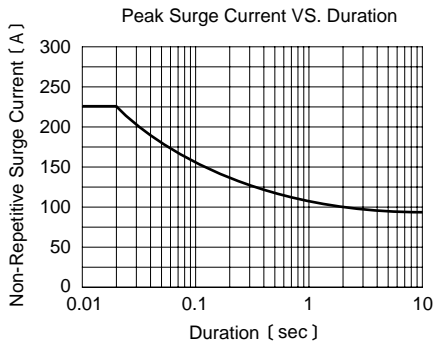

Description in the catalogue is subject to change without notice. Please read the specifications thoroughly before using. Please contact JEL SYSTEM for further information.

Option

Heat-sink

Model	JHC-28-1
SUITABLE SSR	S5C Series

Dimensions

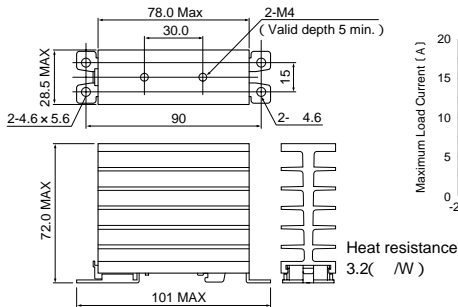

Maximum Load Current VS Ambient Temperature

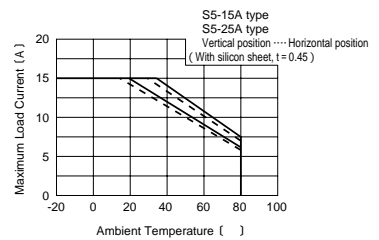
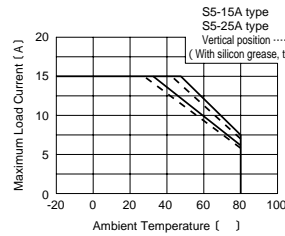

Model	JHC-38-1
SUITABLE SSR	S5C Series

Dimensions

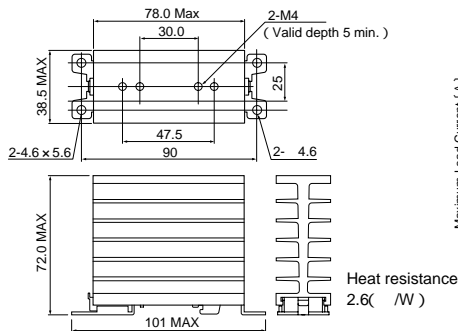

Maximum Load Current VS Ambient Temperature

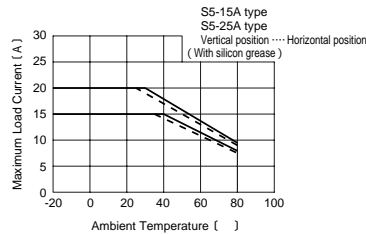

Model	JHA-
SUITABLE SSR	S5C Series

Dimensions

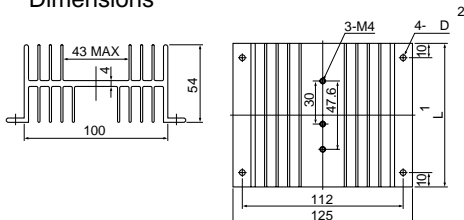

Model	Heat Resistance (/W)	1 L(mm) Dimensions	2 D(mm) Dimensions
JHA-70	1.52	70	4
JHA-100	1.14	100	4
JHA-150	1.00	150	4.5
JHA-200	0.85	200	4

Description in the catalogue is subject to change without notice. Please read the specifications thoroughly before using. Please contact JEL SYSTEM for further information.